



5V POWERED MULTI-CHANNEL RS-232 DRIVERS AND RECEIVERS

- SUPPLY VOLTAGE RANGE: 4.5 TO 5.5V
- SUPPLY CURRENT NO LOAD (TYP): 5mA
- TRANSMITTER OUTPUT VOLTAGE SWING (TYP): $\pm 7.8V$
- CONTROLLED OUTPUT SLEW RATE
- RECEIVER INPUT VOLTAGE RANGE: $\pm 30V$
- DATA RATE (TYP): 220Kbps
- OPERATING TEMPERATURE RANGE:
-40 TO 85 °C, 0 TO 70 °C
- COMPATIBLE WITH MAX232 AND MAX202

DESCRIPTION

The ST232 is a 2 driver, 2 receiver device following EIA/TIA-232 and V.28 communication standard. It is particularly suitable for applications where $\pm 12V$ is not available. The ST232 uses a single 5V power supply and only four external capacitors (0.1 F). Typical applications are in: Portable Computers, Low Power Modems, Interfaces Translation, Battery Powered RS-232 System, Multi-Drop RS-232 Networks.

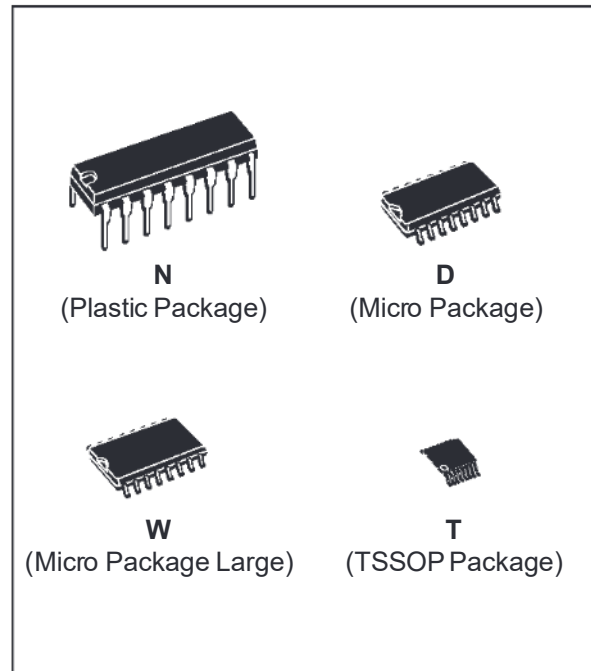

ORDER CODES

Type	Temperature Range	Package	Comments
ST232CN	0 to 70 °C	DIP-16	25 parts per tube / 40 tube per box
ST232BN	-40 to 85 °C	DIP-16	25 parts per tube / 40 tube per box
ST232CD	0 to 70 °C	SO-16 (Tube)	50 parts per tube / 20 tube per box
ST232BD	-40 to 85 °C	SO-16 (Tube)	50 parts per tube / 20 tube per box
ST232CDR	0 to 70 °C	SO-16 (Tape & Reel)	2500 parts per reel
ST232BDR	-40 to 85 °C	SO-16 (Tape & Reel)	2500 parts per reel
ST232CW	0 to 70 °C	SO-16 Large (Tube)	49 parts per tube / 25 tube per box
ST232BW	-40 to 85 °C	SO-16 Large (Tube)	49 parts per tube / 25 tube per box
ST232CWR	0 to 70 °C	SO-16 Large (Tape & Reel)	1000 parts per reel
ST232BWR	-40 to 85 °C	SO-16 Large (Tape & Reel)	1000 parts per reel
ST232CT	0 to 70 °C	TSSOP16 (Tube)	only for samples
ST232BT	-40 to 85 °C	TSSOP16 (Tube)	only for samples
ST232CTR	0 to 70 °C	TSSOP16 (Tape & Reel)	2500 parts per reel
ST232BTR	-40 to 85 °C	TSSOP16 (Tape & Reel)	2500 parts per reel

PIN CONFIGURATION

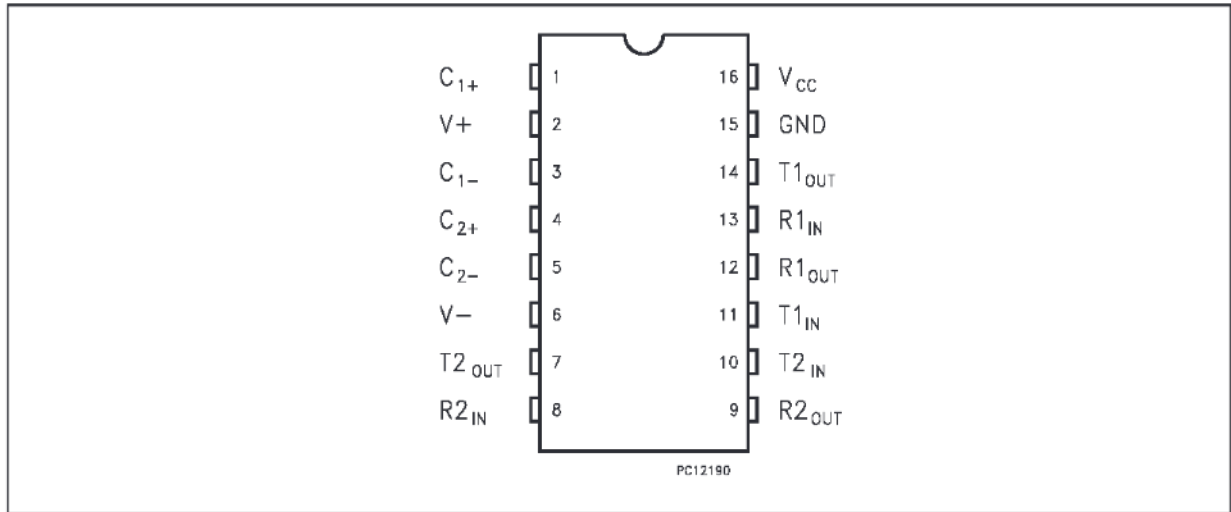

PIN DESCRIPTION

PIN No	SYMBOL	NAME AND FUNCTION
1	C ₁₊	Positive Terminal for the first Charge Pump Capacitor
2	V+	Doubled Voltage Terminal
3	C ₁₋	Negative Terminal for the first Charge Pump Capacitor
4	C ₂₊	Positive Terminal for the second Charge Pump Capacitor
5	C ₂₋	Negative Terminal for the second Charge Pump Capacitor
6	V-	Inverted Voltage Terminal
7	T _{2OUT}	Second Transmitter Output Voltage
8	R _{2IN}	Second Receiver Input Voltage
9	R _{2OUT}	Second Receiver Output Voltage
10	T _{2IN}	Second Transmitter Input Voltage
11	T _{1IN}	First Transmitter Input Voltage
12	R _{1OUT}	First Receiver Output Voltage
13	R _{1IN}	First Receiver Input Voltage
14	T _{1OUT}	First Transmitter Output Voltage
15	GND	Ground
16	V _{CC}	Supply Voltage

ABSOLUTE MAXIMUM RATINGS (Note 1)

Symbol	Parameter	Value	Unit
V _{CC}	Supply Voltage	-0.3 to 6	V
T _{IN}	Transmitter Input Voltage Range	-0.3 to (V _{CC} + 0.3)	V
R _{IN}	Receiver Input Voltage Range	±30	V
T _{OUT}	Transmitter Output Voltage Range	(V ₊ + 0.3) to (V ₋ - 0.3)	V
R _{OUT}	Receiver Output Voltage Range	-0.3 to (V _{CC} + 0.3)	V
T _{SCTOUT}	Short Circuit Duration on T _{OUT}	infinite	
T _{stg}	Storage Temperature Range	-65 to +150	°C

Absolute Maximum Ratings are those values beyond which damage to the device may occur. Functional operation under these condition is not implied.
 Note1: No external supply can be applied to V+ terminal and V- terminal.

ELECTRICAL CHARACTERISTICS(C₁ -C₄ = 0.1 F, V_{CC} = 5V ± 10% T_A = -40 to 85 °C, unless otherwise specified.Typical Values are referred to T_A = 25 °C)

Symbol	Parameter	Test Conditions	Value			Unit
			Min.	Typ.	Max.	
I _{SUPPLY}	V _{CC} Power Supply Current	No Load, T _A = 25 °C		5	10	mA

TRANSMITTER ELECTRICAL CHARACTERISTICS(C₁ -C₄ = 0.1 F, V_{CC} = 5V ± 10%, T_A = -40 to 85 °C, unless otherwise specified.Typical Values are referred to T_A = 25 °C)

Symbol	Parameter	Test Conditions	Value			Unit
			Min.	Typ.	Max.	
V _{TOUT}	Output Voltage Swing	All Transmitter outputs are loaded with 3KΩ to GND	±5	±7.8		V
I _{TIL}	Logic Pull-Up Current	T _{IN} = 0 V		15	200	A
V _{TIL}	Input Logic Threshold Low				0.8	V
V _{TIH}	Input Logic Threshold High		2			V
SR _T	Transition Slew Rate	T _A = 25 °C, V _{CC} = 5 V, R _L = 3 to 7 KΩ, C _L = 50 to 2500 pF (Note 1)		7	30	V/ s
D _R	Data Rate	(Note 2)	120	220		Kbits/s
R _{TOUT}	Transmitter Output Resistance	V _{CC} = V ₊ = V ₋ = 0V V _{OUT} = ± 2 V	300			Ω
I _{SC}	Transmitter Output Short Circuit Current	one T _{XOUT} to GND		±10	±60	mA

Note 1: Measured from 3V to -3V or from -3V to 3V.

Note 2: One transmitter output is loaded with R_L = 3KΩ to 7KΩ, C_L = 50 to 1000pF**RECEIVER ELECTRICAL CHARACTERISTICS**(C₁ -C₄ = 0.1 F, V_{CC} = 5V ± 10%, T_A = -40 to 85 °C, unless otherwise specified.Typical Values are referred to T_A = 25 °C)

Symbol	Parameter	Test Conditions	Value			Unit
			Min.	Typ.	Max.	
V _{RIN}	Receiver Input Voltage Operating Range		-30		30	V
R _{RIN}	RS-232 Input Resistance	T _A = 25 °C, V _{CC} = 5 V, V _{RIN} = 5 V	3	5	7	KΩ
V _{RIL}	RS-232 Input Logic Threshold Low	T _A = 25 °C, V _{CC} = 5 V	0.8	1.2		V
V _{RIH}	RS-232 Input Logic Threshold High	T _A = 25 °C, V _{CC} = 5 V		1.7	2.4	V
V _{RIHYS}	RS-232 Input Hysteresis	V _{CC} = 5 V	0.2	0.5	1	V
V _{ROL}	TTL/CMOS Output Voltage Low	I _{OUT} = 3.2mA (to V _{CC})			0.4	V
V _{ROH}	TTL/CMOS Output Voltage High	I _{OUT} = 1mA (to GND)	3.5	V _{CC} -0.4		V
t _{dR}	Propagation Delay Time	C _L = 150pF (Note 1)		0.3	1	s
I _{SCR}	Receiver Output Short Circuit Current			±10		mA

Note 1: RS-232 IN to TTL-CMOS OUT (from 50% to 50%)

APPLICATION CIRCUITS (note 1, note 2)

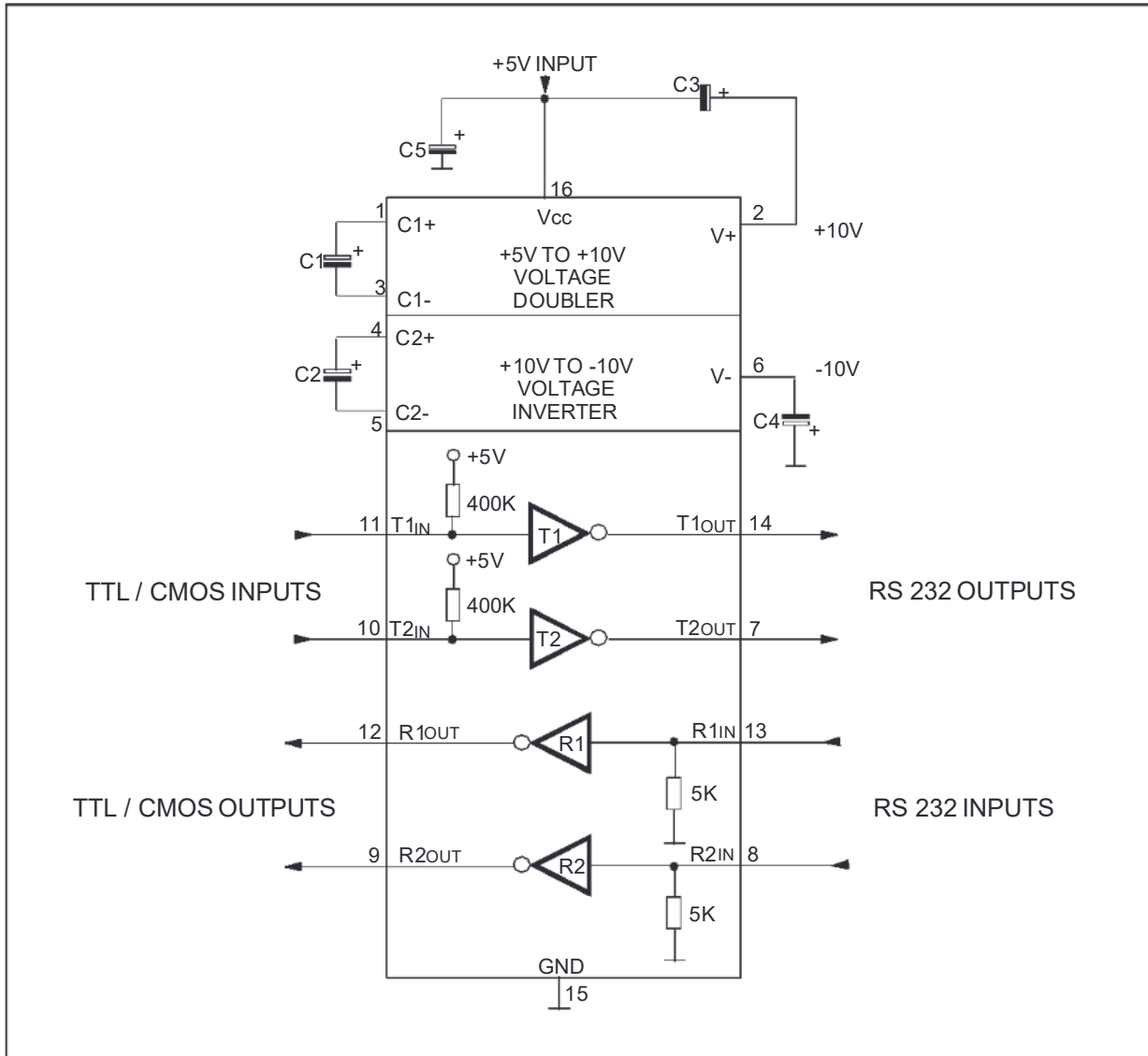

Note 1: C₁₋₄ capacitors can even be 1 F ones.
 Note 2: C₁₋₄ can be common or biased capacitors.

Capacitance Value (F)

C1	C2	C3	C4	C5
0.1	0.1	0.1	0.1	0.1

Supply Current vs Temperature

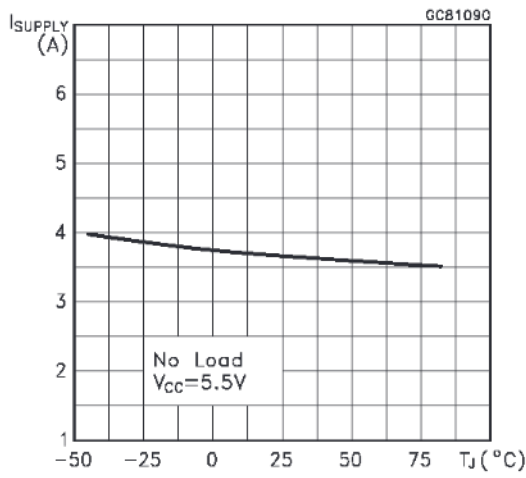

Data Rate vs Temperature

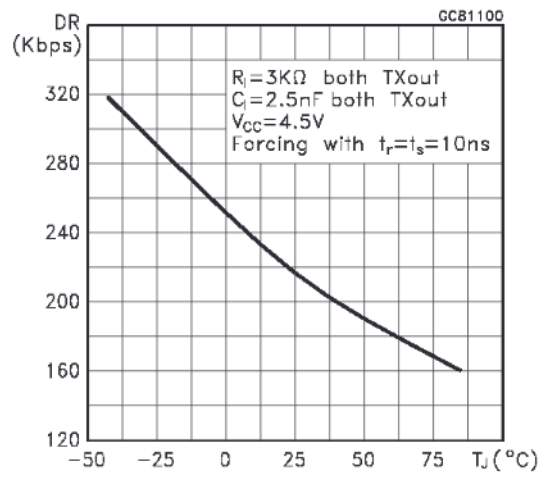

Receiver Propagation Delay

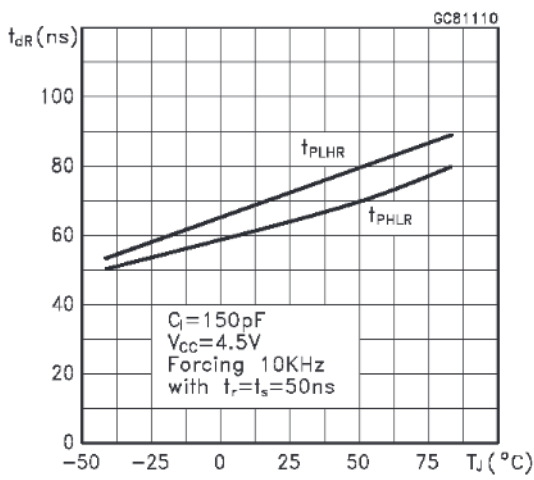

Driver Propagation Delay

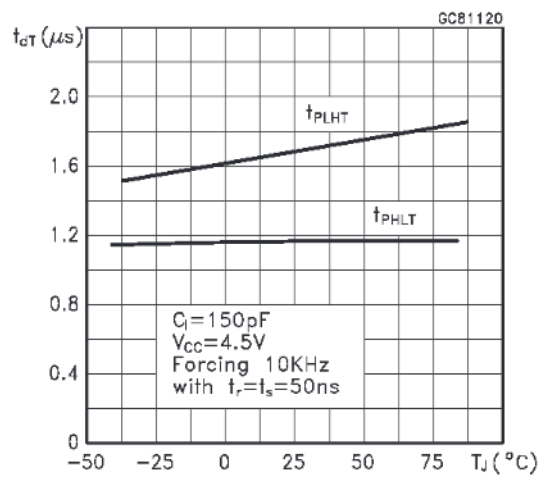

High Level Output Voltage Swing vs Temperature

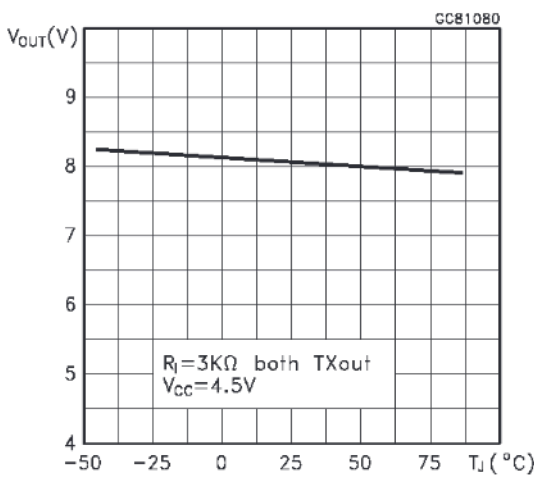

Low Level Output Voltage Swing vs Temperature

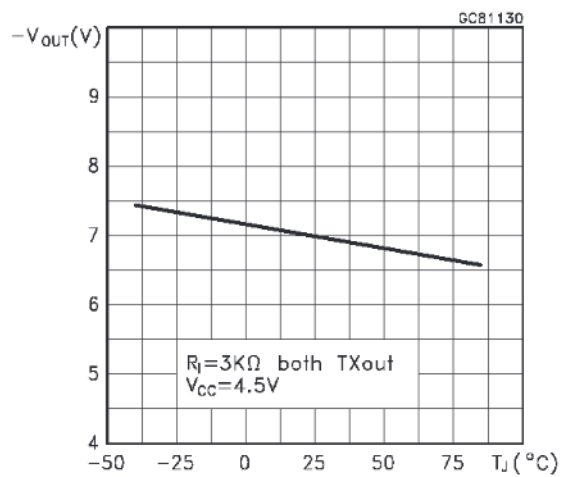

High Level Trasmmitter Output Short Circuit Current vs Temperature

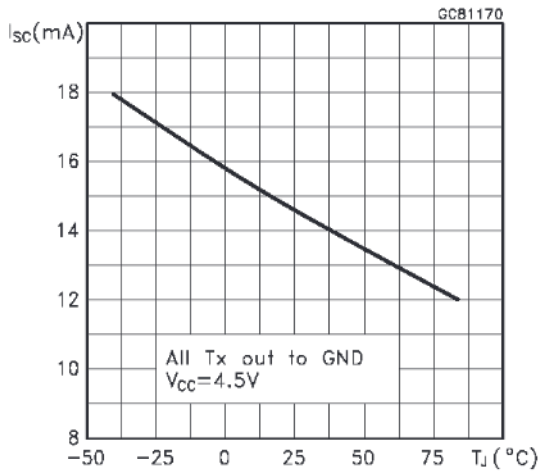

Low Level Trasmmitter Output Short Circuit Current vs Temperature

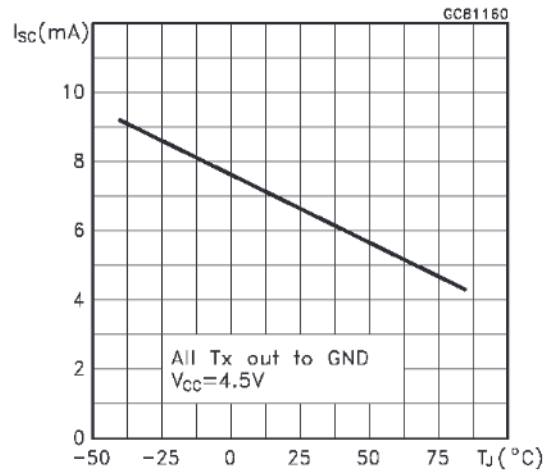

High Level Receiver Output Short Circuit Current vs Temperature

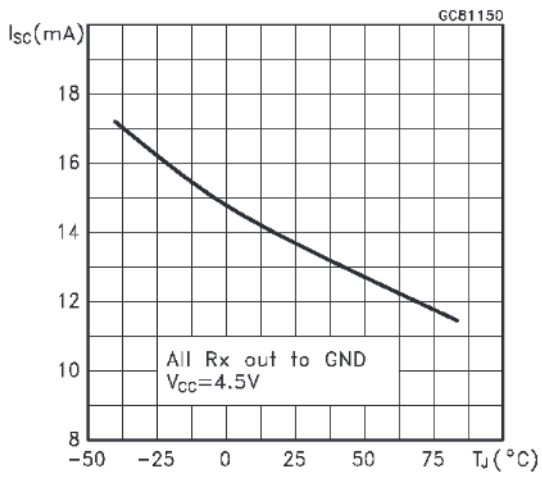

Low Level Receiver Output Short Circuit Current vs Temperature

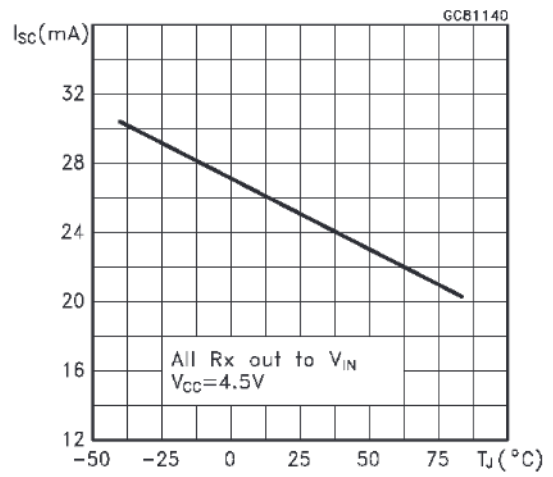

Plastic DIP-16 (0.25) MECHANICAL DATA

DIM.	mm			inch		
	MIN.	TYP.	MAX.	MIN.	TYP.	MAX.
a1	0.51			0.020		
B	0.77		1.65	0.030		0.065
b		0.5			0.020	
b1		0.25			0.010	
D			20			0.787
E		8.5			0.335	
e		2.54			0.100	
e3		17.78			0.700	
F			7.1			0.280
l			5.1			0.201
L		3.3			0.130	
Z			1.27			0.050

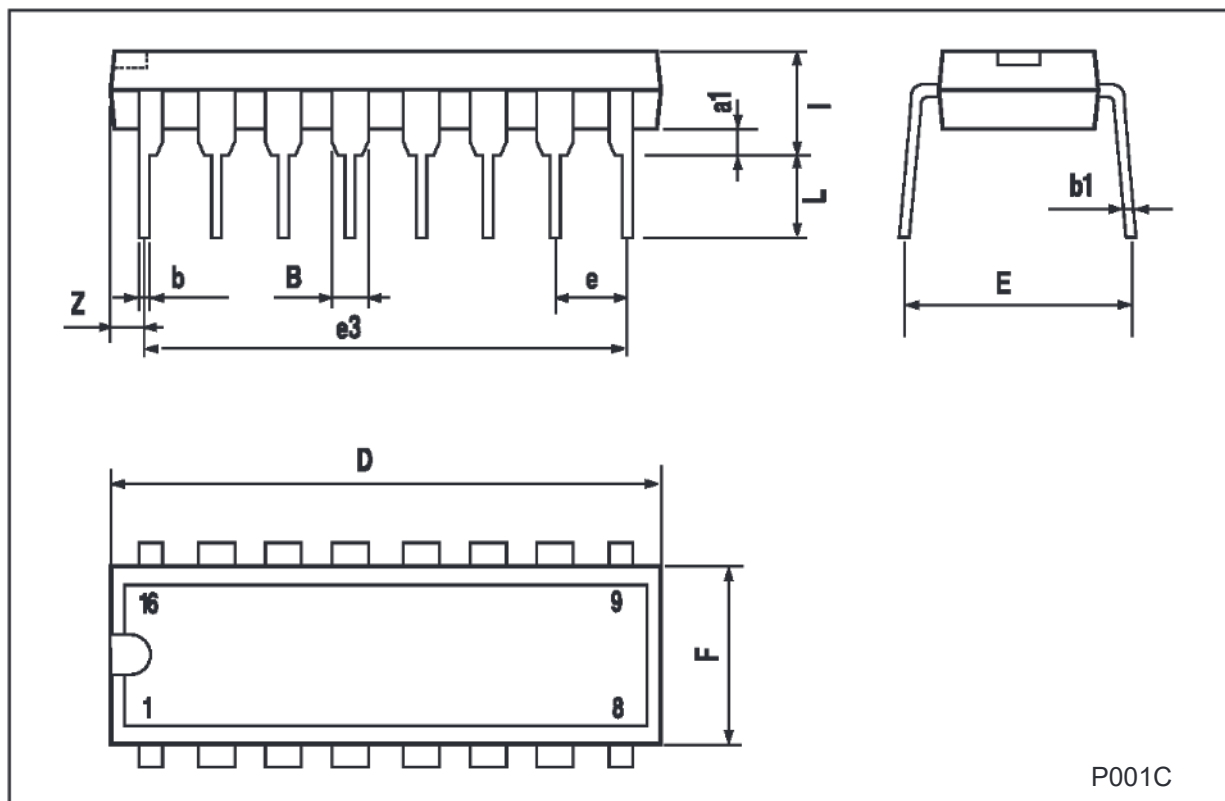

P001C

SO-16 MECHANICAL DATA

DIM.	mm			inch		
	MIN.	TYP.	MAX.	MIN.	TYP.	MAX.
A			1.75			0.068
a1	0.1		0.2	0.004		0.007
a2			1.65			0.064
b	0.35		0.46	0.013		0.018
b1	0.19		0.25	0.007		0.010
C		0.5			0.019	
c1	45 (typ.)					
D	9.8		10	0.385		0.393
E	5.8		6.2	0.228		0.244
e		1.27			0.050	
e3		8.89			0.350	
F	3.8		4.0	0.149		0.157
G	4.6		5.3	0.181		0.208
L	0.5		1.27	0.019		0.050
M			0.62			0.024
S	8 (max.)					

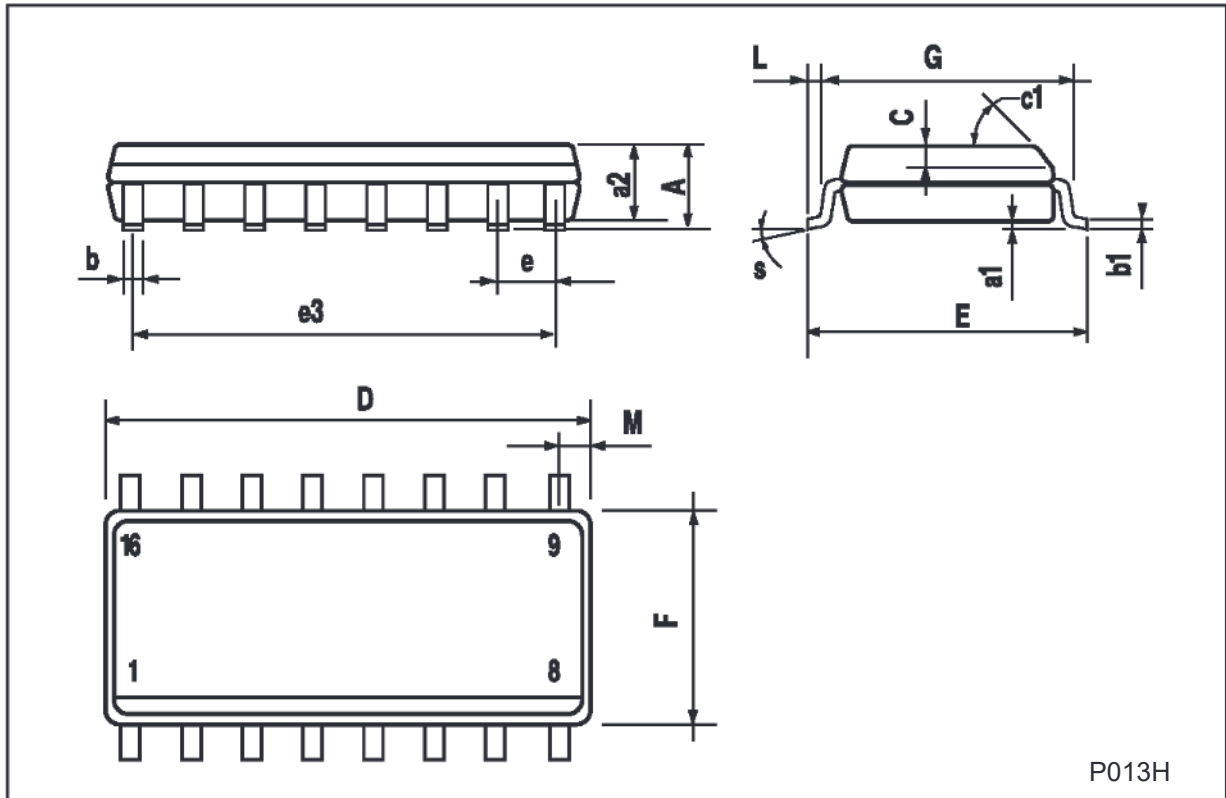

P013H

SO16L MECHANICAL DATA

DIM.	mm			inch		
	MIN.	TYP.	MAX.	MIN.	TYP.	MAX.
A			2.65			0.104
a1	0.1		0.2	0.004		0.008
a2			2.45			0.096
b	0.35		0.49	0.014		0.019
b1	0.23		0.32	0.009		0.012
C		0.5			0.020	
c1	45 (typ.)					
D	10.1		10.5	0.397		0.413
E	10.0		10.65	0.3.93		0.419
e		1.27			0.050	
e3		8.89			0.350	
F	7.4		7.6	0.291		0.300
L	0.5		1.27	0.020		0.050
M			0.75			0.029
S	8 (max.)					

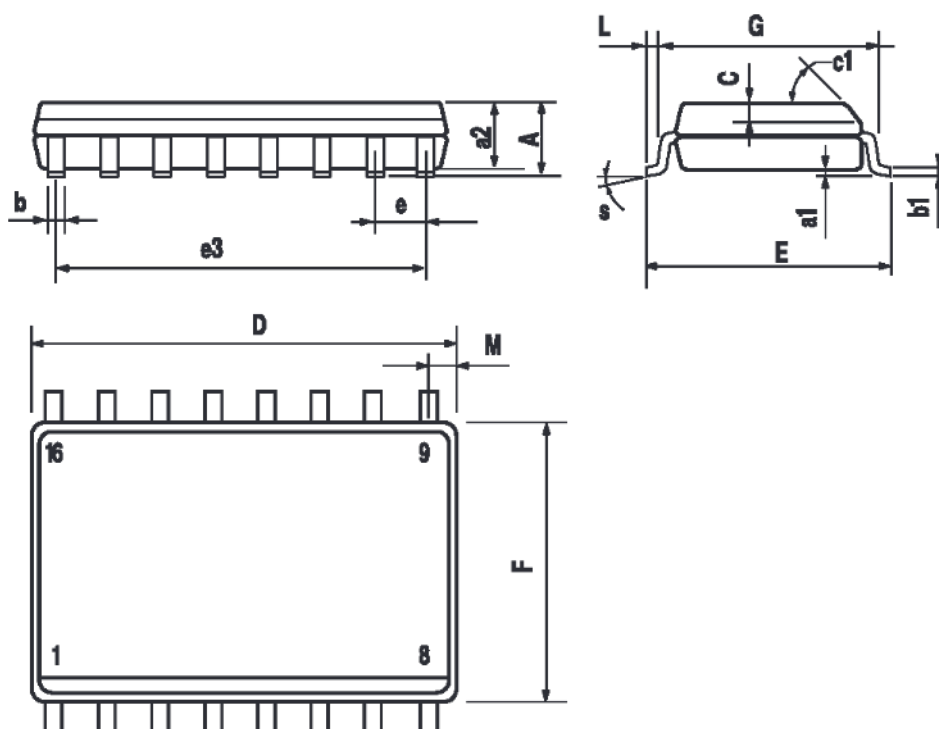

P0131

TSSOP16 MECHANICAL DATA

DIM.	mm			inch		
	MIN.	TYP.	MAX.	MIN.	TYP.	MAX.
A			1.1			0.433
A1	0.05	0.10	0.15	0.002	0.004	0.006
A2	0.85	0.9	0.95	0.335	0.354	0.374
b	0.19		0.30	0.0075		0.0118
c	0.09		0.20	0.0035		0.0079
D	4.9	5	5.1	0.193	0.197	0.201
E	6.25	6.4	6.5	0.246	0.252	0.256
E1	4.3	4.4	4.48	0.169	0.173	0.176
e		0.65 BSC			0.0256 BSC	
K	0°	4°	8°	0°	4°	8°
L	0.50	0.60	0.70	0.020	0.024	0.028

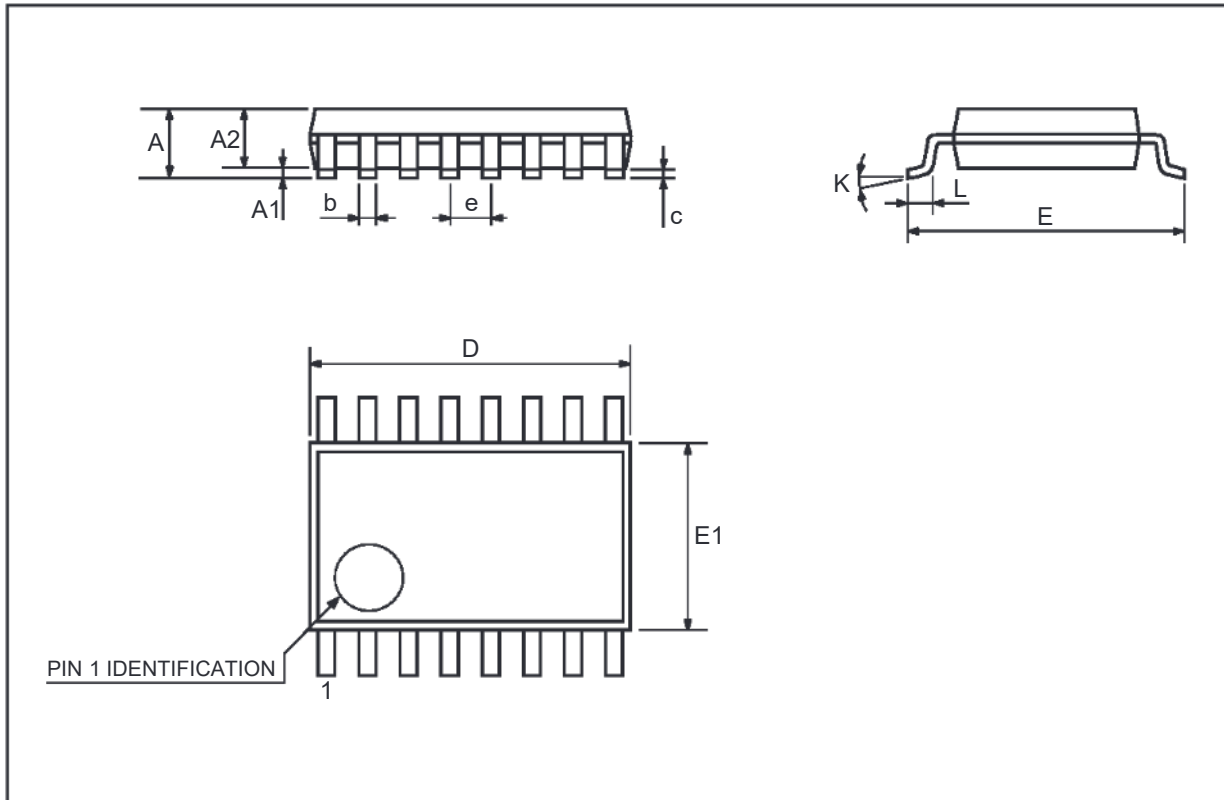

Information furnished is believed to be accurate and reliable. However, STMicroelectronics assumes no responsibility for the consequences of use of such information nor for any infringement of patents or other rights of third parties which may result from its use. No license is granted by implication or otherwise under any patent or patent rights of STMicroelectronics. Specification mentioned in this publication are subject to change without notice. This publication supersedes and replaces all information previously supplied. STMicroelectronics products are not authorized for use as critical components in life support devices or systems without express written approval of STMicroelectronics.

The ST logo is a registered trademark of STMicroelectronics

© 2001 STMicroelectronics – Printed in Italy – All Rights Reserved

STMicroelectronics GROUP OF COMPANIES

Australia - Brazil - China - Finland - France - Germany - Hong Kong - India - Italy - Japan - Malaysia - Malta - Morocco
Singapore - Spain - Sweden - Switzerland - United Kingdom - U.S.A.

<http://www.st.com>

